

# FUTURE TRENDS IN FIBER OPTICS COMMUNICATION

Dr. Subhadra Rajpoot, Dr. Preeti Singh , Seffali Solanki and Shaikh Juned Yasin

Department of Chemistry, Amity University, Greater Noida, India

## **ABSTRACT**

*Fiber optic systems are vital media transmission foundation for overall broadband systems. Wide data transfer capacity (bandwidth) signal transmission with low delay is a key prerequisite in present day applications. Optical fiber give broad and incomparable transmission transfer speed with insignificant expectations, and are currently the transmission medium of decision for long separation and high information rate transmission in media transmission systems. This paper gives a review of fiber optic communication system, including their key advances, and furthermore talks about their mechanical pattern towards the next generation.*

## **KEYWORDS**

*Bandwidth, Broadband, Fiber optics, Latency, Telecommunication*

## **1.INTRODUCTION**

The significant main impetus behind the broad utilization of fiber optics communication is the high and quickly expanding users and business interest for more media transmission ability and web administrations with fiber optic innovation, able for giving the required data limit (greater than both wireless connections and copper link). Progresses in innovation have empowered more information to be passed on through a single optical fiber over long separations. The transmission limit in optical communication systems are fundamentally enhanced utilizing wavelength division multiplexing. A desirable component for future optical systems is the capacity to process data totally in the optical area with the end goal of amplification, multiplexing, de-multiplexing, exchanging, separating, and co-relation, since optical signal preparing is more effective than electrical signal processing.

A few new classes of optical communication systems are by and by developing. For instance, Code Division Multiple Access systems utilizing optical signal preparing procedures have recently presented.

## **2. BASIC PRINCIPLES OF FIBER OPTIC COMMUNICATION**

The information in form of light pulses are transferred from one to another point for communication in optical fiber. The information is generated in digital form by using telephone and computer systems. An optical fiber is a non-conducting cylindrical dielectric waveguide which transmits light along its axis, it is made of low-loss material usually silicon dioxide. Fiber optics transmits light (signal) by the process of total internal reflection (TIR).

The innermost part of waveguide called as core and it is covered by outer medium (cladding). The core has a little higher refractive index than cladding. Input data in the form of electrical signal is converted in optical signal by optical transmitter. A cable containing several bundle of optical fiber are used to transmit or transfer this optical signal to the receiver, optical amplifier are

International Journal on Cybernetics & Informatics (IJCI) Vol. 6, No. 1/2, April 2017  
 used to boost the power of optical signal. Optical receiver reconverts the optical signal into the original electrical signal. Figure 1 gives a simple description, of a fiber optic communication system.

Figure 1 gives an improved portrayal of a fundamental fiber optic correspondence framework.

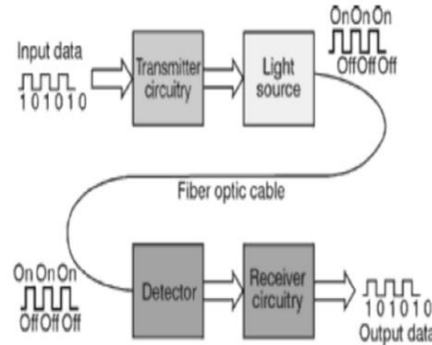

Figure 1. Essential fiber optic correspondence framework [5]

Optical fiber is categorized into two types, first step index optical fiber, and second graded index optical fiber. Step index optical fiber consists of two types, single mode fiber and multimode fiber. The most common type of single mode step index optical fiber have a core diameter of 8-10 micrometers , and is used in the flow of one light path. Multimode step index optical fiber, with large core diameter greater than 50 micrometers are used to flow several light paths. This leads to modal dispersion. The graded index fiber, the index of refraction in the core decreases continuously between the axis and the cladding. This flows the speed of some light rays. This causes all the light rays to reach the receiver at almost the same time by reducing dispersion.

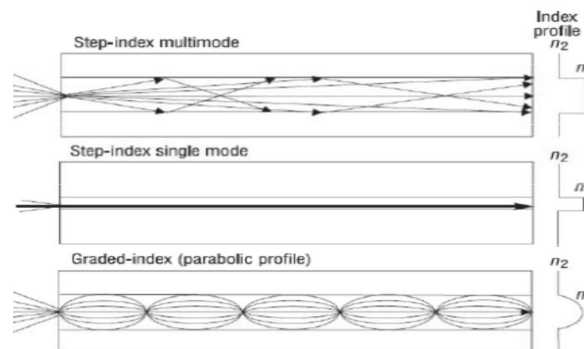

Figure 2 gives a description of the various optical fiber modes.

### 3. EVOLUTION OF FIBER OPTICS COMMUNICATION

Optical fiber was initially created in 1970 by Corning Glass Works. In the meantime, GaAs semiconductor lasers were additionally produced for transmitting light through the fiber optic links. The original fiber optic framework was created in 1975, it utilized GaAs semiconductor lasers, worked at a wavelength of 0.8  $\mu\text{m}$ , and bit rate of 45Megabits/second with 10Km repeater dispersing. In the mid 1980's, the second era of fiber optic correspondence was produced, it

utilized InGaAsP semi conductor lasers and worked at a wavelength of 1.3  $\mu\text{m}$ . By 1987, these fiber optic frameworks were working at bit rates of up to 1.7 Gigabits/second on single mode fiber with 50Km repeater separating. The third era of fiber optic correspondence working at a wavelength of 1.55  $\mu\text{m}$  was produced in 1990. These frameworks were working at a bit rate of up to 2.5 Gigabits/second on a solitary longitudinal mode fiber with 100Km repeater separating. The fourth era of fiber optic frameworks made utilization of optical speakers as a substitution for repeaters, and used wavelength division multiplexing (WDM) to expand information rates. By 1996, transmission of more than 11,300Km at an information rate of 5Gigabits/second had been exhibited utilizing submarine links [7].

The fifth era fiber optic correspondence frameworks utilize the Dense Wave Division Multiplexing (DWDM) to further expand information rates. Additionally, the idea of optical solitons, which are heartbeats that can safeguard their shape by balancing the negative impacts of scattering, is likewise being investigated.

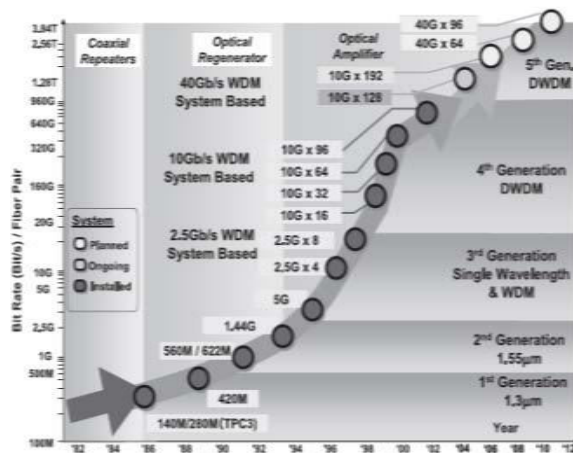

Figure 3 demonstrates the development of fiber optic correspondence.

## 4. FUTURE TRENDS IN FIBER OPTICS COMMUNICATION

Fiber optics correspondence is certainly the eventual fate of information correspondence. The development of fiber optic correspondence has been driven by progression in innovation and expanded interest for fiber optic correspondence. It is required to proceed into the future, with the improvement of new and more propelled correspondence innovation. The following are a portion of the imagined future patterns in fiber optic correspondence.

### 4.1 All Optical Communication Networks

An all fiber optic correspondence is imagined which will be totally in the optical space, offering ascend to an all optical correspondence organize. In such systems, all signs will be prepared in the optical area, with no type of electrical control. By and by, handling and exchanging of signs happen in the electrical area, optical signs should first be changed over to electrical flag before they can be prepared, and directed to their goal. After the preparing and steering, the signs are then re-changed over to optical signs, which are transmitted over long separations to their goal. This optical to electrical change, and the other way around, results in included inertness the system and subsequently is a constraint to accomplishing high information rates.

## **4.2 Multi – Terabit Optical Networks**

Thick Wave Division Multiplexing (DWDM) makes ready for multi-terabit transmission. The overall requirement for expanded transmission capacity accessibility has prompted to the enthusiasm for creating multi-terabit optical systems. By and by, four terabit systems utilizing 40Gb/s information rate consolidated with 100 DWDM channels exists. Scientists are taking a gander at accomplishing significantly higher data transmission with 100Gb/s. With the persistent diminishment in the cost of fiber optic segments, the accessibility of substantially more noteworthy transmission capacity later on is conceivable.

## **4.3 Intelligent Optical Transmission Network**

By and by, conventional optical systems are not ready to adjust to the quick development of online information benefits because of the unconventionality of element assignment of data transmission, customary optical systems depend mostly on manual setup of system network, which is time expending, and not able to completely adjust to the requests of the cutting edge organize. Smart optical system is a future pattern in optical system improvement [2], and will have the accompanying applications: movement designing, dynamic asset course allotment, uncommon control conventions for system administration, adaptable flagging abilities, data transmission on request, wavelength rental, wavelength discount, separated administrations for an assortment of Quality of Service levels, et cetera. It will require some investment before the wise optical system can be connected to all levels of the system, it will first be connected in whole deal systems, and continuously be connected to the system edge.

## **4.4 Ultra – Long Haul Optical Transmission**

In the region of ultra-whole deal optical transmission, the impediments forced because of defects in the transmission medium are subject for research. Cancellation of scattering impact has incited analysts to concentrate the potential advantages of soliton spread. Additional comprehension of the associations between the electromagnetic light wave and the transmission medium is important to continue towards a framework with the most good conditions for a light heartbeat to proliferate [11].

## **4.5 Laser Neural Network Nodes**

The laser neural system is a powerful choice for the acknowledgment of optical system hubs. A devoted equipment arrangement working in the optical space and the utilization of ultra-quick photonic segments is required to additionally enhance the limit and speed of media transmission systems [12]. As optical systems turn out to be more perplexing later on, the utilization of optical laser neural hubs can be a viable arrangement.

## **4.6 Polymer Optic Fibers**

Polymer optical filaments offer many advantages when contrasted with other information correspondence arrangements, for example, copper links, remote correspondence frameworks, and glass fiber. In examination with glass optical filaments, polymer optical strands give a simple and less costly preparing of optical flags, and are more adaptable for fitting interconnections [13]. The utilization of polymer optical filaments as the transmission media for air ships is by and by under research by various Research and Development amasses because of its advantages. The German Aerospace Center have presumed that "the utilization of Polymer Optical Fibers mixed media strands seems, by all accounts, to be workable for future flying machine applications [14].

#### **4.7 Improvements in Optical Transmitter/Receiver Technology**

In fiber optics correspondence, it is imperative to accomplish excellent transmission notwithstanding for optical signs with contorted waveform and low flag to commotion proportion amid transmission. Research is progressing to create optical handsets receiving new and propelled tweak innovation, with superb chromatic scattering and Optical Signal to Noise Ratio (OSNR) resilience, which will be appropriate for ultra-whole deal correspondence frameworks. Additionally, better mistake rectification codes, which are more proficient than the present BCH linked codes are imagined to be accessible in the closest future.

#### **4.7 Improvements in Glass Fiber Design and Component Miniaturization**

By and by, different polluting influences are included or expelled from the glass fiber to change its light transmitting attributes. The outcome is that the speed with which light goes along a glass fiber can be controlled, in this way taking into consideration the creation of altered glass strands to meet the particular activity building prerequisite of a given course. This pattern is expected to proceed later on, with a specific end goal to create more solid and compelling glass filaments. Likewise, the scaling down of optical fiber correspondence segments is another pattern that is well on the way to proceed later on.

### **5. CONCLUSIONS**

The fiber optics interchanges industry is an always developing one, the development experienced by the business has been tremendous this previous decade. There is still much work to be done to bolster the requirement for quicker information rates, progressed exchanging procedures and more shrewd system structures that can consequently change progressively in light of activity examples and in the meantime be cost proficient. The pattern is relied upon to proceed later on as leaps forward effectively achieved in the research facility will be reached out to viable organization subsequently prompting to another era in fiber optics interchanges.

### **REFERENCES**

- [1] M. Noshada, A. Rostami, "FWM minimization in WDM optical communication systems using the asymmetrical dispersion managed fibers", *International Journal for Light and Electron Optics*, vol. 123, no. 9, pp. 758– 760, 2012.
- [2] X. Wang and K. Kitayama, "Analysis of beat noise in coherent and incoherent time-spreading OCDMA," *IEEE/OSA Journal of Lightwave Technology* ,vol. 22, no. 10, pp. 2226-2235, 2004.
- [3] T. H. Shake, "Confident performance of encoded optical CDMA", *IEEE/OSA Journal of Lightwave Technology*, vol. 23, pp. 1652- 1663, 2005.
- [4] Prachi Sharma et al, "A Review of the Development in the Field of Fiber Optic Communication Systems", *International Journal of Emerging Technology and Advanced Engineering*, Vol. 3, no. 5, pp. 113-119, 2013.
- [5] G. Keiser, op cit, p 51
- [6] Franz Fidler, Markus Knapek, Joachim Horwath, and Walter R.Leeb, "Optical Communications for High-Altitude Platforms", *IEEE Journal of Selected Topics in Quantum Electronics*, Vol. 16, no. 5, September/October 2010.
- [7] T. Otani, K. Goto, H. Abe, M. Tanaka, H. Yamamoto, and H.Wakabayashi, *Electron. Lett.*31, 380, 1995.

## Authors

Dr. Subhadra Rajpoot is currently working as assistant professor in Amity University Greater Noida . . Her current research interests include analytical chemistry, Nano chemistry and many more related to environment. Dr. rajpoot is a Fellow of the Indian National Academy of Engineering; the National Academy of Science, India; She is a Life Member of the Indian Society for Socio Techno Welfar(ISST). She is the member of editorial board & reviewer of various reputed Journals like

- International Journal of Innovative research in science & engineering
- International journal of Electrical & Electronics engineers
- International Journal of Science Technology & management
- International Journal of Advanced Technology in Engg. & Science
- International Journal of Advance Research in Science & Engg.

