

POWER STABILITY ANALYSIS OF A TRANSMISSION SYSTEM WITH A UNIFIED POWER FLOW CONTROLLER USING TRANSFORMATIVE INTRINSIC ALGORITHM

Sindhu. K

Department of Information and Communication Engineering,
Sona College of Technology, Salem, India.

ABSTRACT

The unified power quality conditioner is the equipment used for regulated voltage distortion and voltage unbalance in a power system. UPFC can enhance the power to flow through the transmission system by controlling the power flow and voltage stability of the transmission line within their limits. This paper presents a control scheme and Theoretical derivation of the unified power flow conditioner and the simulation results are compared and contrasted in detail. UPFC is a combination of shunt Active and series active power filters. UPFC contains a DC link capacitor in a single-phase voltage source inverter with two back to back connected, three-phase three-wire and three-phase four-wire are arranged. The fundamental target of this work is to determine the causes and impacts of power quality problems, specifically voltage sag, voltage swell, power factor, and Total Harmonics Distortion (THD) and enhance the power quality of a transmission system by UPFC based Transformative Intrinsic Algorithm (TIA). The Simulation of the proposed method is developed by Mat lab Simulink software, and the simulation result shows, the proposed method gives better solutions to control the power imbalance in the distribution system with its cost-effectiveness.

KEYWORDS

Unified power flow Damping Controller, Point of Connection (POC), Transformative Intrinsic Algorithm (TIA) Logic Power System Stabilizer (FLPSS), ANFIS, Proportional Controller, Total Harmonic Distortion (THD), Damping Ratio.

1. INTRODUCTION

In a modern power system, the installation of comprehensive and non-linear electronic equipment causes the various power quality (PQ) problems in transmission systems like sag voltage, harmonics, flicker, etc. are responsible for distorting the supply voltage and nature of the current waveform. Thus PQ problems degrade the performance of these sensitive loads like electric drives, computer systems, and industrial electronic controllers. The fundamental target of this work needs to enhance the power quality of a transmission line by improving the real and reactive power flow, mitigation of voltage sag and swell, and reduction in THD using Unified Power Flow Controller (UPFC) for based on Transformative Intrinsic Algorithm (TIA) control algorithms. So UPFC is a versatile FACTS device, capable of improving the stability of a power transmission system with a suitable design. The effectiveness of the proposed model is to determine the causes and impacts of power quality problems, specifically voltage sag mitigation, power factor, and Total Harmonics Distortion (THD) and delicately improve the power quality

parameter like frequency, voltage, current in the transmission line and it's established with a non-linear period.

A general introduction to the basic operating principle of UPFC and UPFC Power Controller and their tuning has been discussed. In this work, Existing modelling techniques for the UPFC together with the associated control strategies have been systematically reviewed. UPFC contains a back- to -back DC voltage source converters are driven from a DC digital source capacitor with three-phase three-wire and three-phase four-wire arrangement. An exact power injection model is proposed which is based on the polar representation of the UPFC parameters and includes the reactive power capability of the shunt inverter. The UPFC internal limits have been identified and accordingly, the feasible operating area of a transmission system incorporating system has been determined based on the UPFC maximum limits. The impact of a change in the system's short circuit level on the UPFC operation and the size of the feasible area have also been investigated. The influence of both the series and shunt inverters on this controlled area has been analysed. The modern controllers have been designed and tested for controlling the UPFC in a power flow model for the series part and a voltage control mode for the shunt part. Shunt converter provides active power demand within a common DC link. The function of Series Converter is to produce reactive power in the transmission line by injecting a voltage with controllable magnitude and phase angle to compensate for the transmission loss and load stability. The system focus on the improvement of the real and reactive power flow, mitigation of voltage sag, voltage swell, Power factor, THD in the transmission line.

2. UNIFIED POWER FLOW CONTROLLER

One of the most versatile FACTS controller device is Unified Power Flow Controller (UPFC), can change system's electrical quantity such as voltage, impedance, phase angle and improve the power of a transmission line by maintaining the security, stability, and reliability of power system by injecting a voltage with controllable magnitude and phase angle to the transmission line.

Here the basic design and control blocks of UPFC are explained together with the operating modes. UPFC compensates for phase-shifting and reactive power. UPFC with two voltage source converters connected back-to-back and are driven by a common DC digital source capacitor is shown in figure 2.1. A sinusoidal voltage injected in series and a shunt to the transformer. The shunt converter is used to provide active power demand through a common DC link of the series converter and also produces reactive power in the transmission line to compensate for the transmission loss and load stability. The second converter is connected in series with the line.

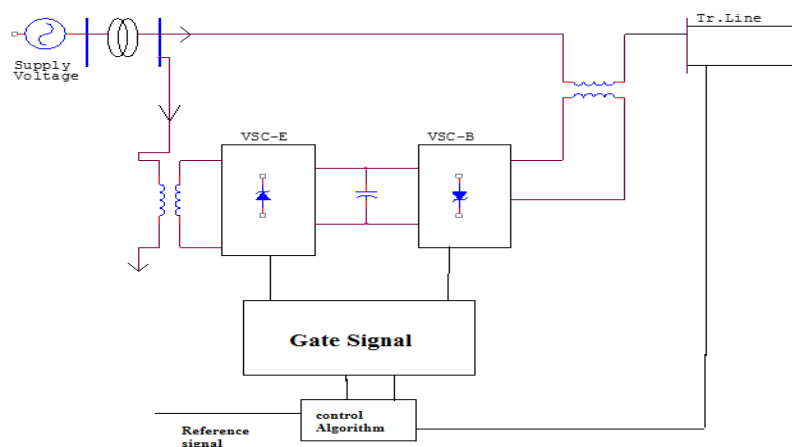

Figure 2.1 UPFC structure

A. Voltage Source Converter

There are two types of converters in UPFC application, Voltage Source Converter (VSC) and Current Source Converter (CSC). Voltage Source Converter uses a capacitor for energy storage. It is a highly efficient fast dynamic response and relatively easy to control. Due to higher conduction loss and more complicated to control the CSC, the VSC is the dominant topology in Flexible Alternating Current Transmission system (FACTS) application.

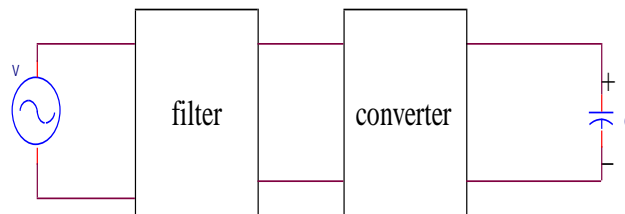

Figure 2.2 Voltage source converter

B. Current Source Converter

The inductor is the storage equipment in the current source converter. CSC has the various advantages of lower output dv/dt , easy regeneration capability and implicit short-circuit protection. In high power applications superconducting device is used as storage with suitable switching capacity.

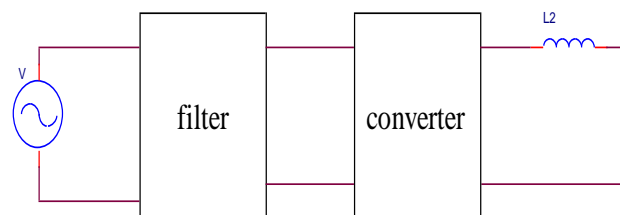

Figure 2.3 Current source converter

C. Three-Phase Voltage-Source Converter

Figure 2.4 shows a typical three-phase voltage-source converter with six switching devices. The switching devices used in the diagram are MOSFETs. The converter has three phase-legs and operates at 120 degrees. The voltages are bus voltages concerning hypothetical DC capacitor midpoint labeled as Neutral in Figure 2.4 Line voltages V_{ab} , V_{bc} , V_{ca} have peak voltage as V_{dc} . The three-line voltages have pulse-width variations. The hypothetical neutral voltage $V_n = 3(V_a + V_b + V_c)$, and its peak value are $V_{dc}/6$.

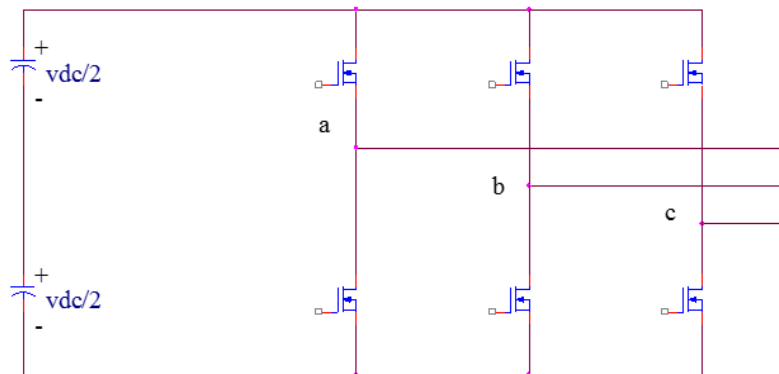

Figure 2.4 Three-phase voltage-source converter

D. Shunt Active Power Filter

The shunt APF is used to compensate distortions and harmonics which are currently being developed due to non-linear loads and make the current source sine curve is completely free of distortions. The modulation of the current in a transmission line is varying by the hysteresis band. In PWM modulation the converter will analyze the hysteresis band of the reference and current output current which varies the reactive power of the system. Shunt APF generates reference compensating current and gating signals by hysteresis current controller.

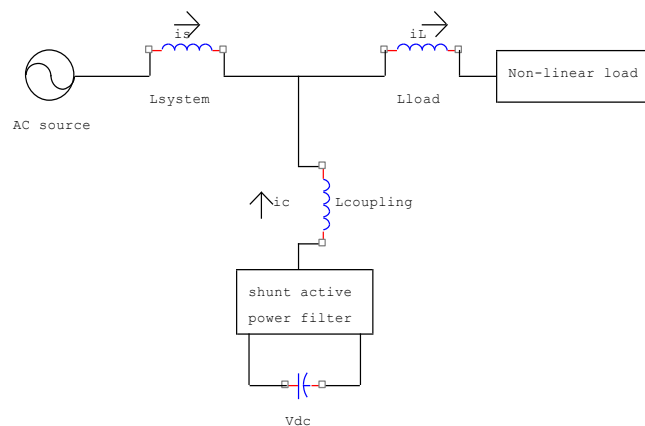

Figure 2.5 Block diagram of shunt APF

E. Series Active Power Filter

A Series Active Power Filter is used to mitigate the voltage distortions caused due to voltage unbalance in the voltage source. Series APF is connected in series with a series transformer with the transmission line. The voltage distortions mean voltage dip, voltage rise, voltage fluctuations, voltage flicker are removed from voltage source employing Series APF. The Basic Structure of Series APF Contains Series Transformer, DC Voltage regulator, Voltage source inverter, Hysteresis Voltage controller. Series APF Generate reference compensating voltage and Comparing reference compensating voltage with actual hysteresis voltage and generates PWM signal for compensating voltage source inverter.

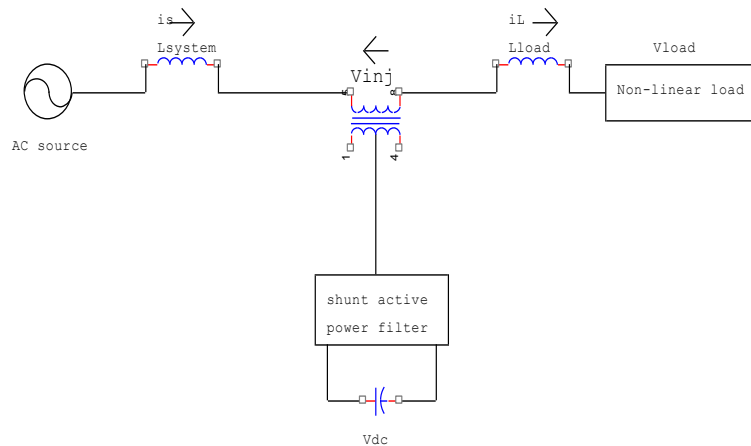

Figure 2.6 Block Diagram of Series APF

3. CONTROL SYSTEM HIERARCHY OF A CUPFC

Centralized Unified Power Flow Controller (CUPFC) is developed from vector control based on the d-q transformation used in STATCOM. An additional control loop and a pre-control signal used to increase the stability and transient system performance. The transient performance of the CUPFC can be improved by coordinating the real and reactive power between the shunt and the series converter. The UPFC has several operating modes depending upon operations. There are two modes of operations in shunt converter, Volt Ampere Reactive (VAR) control mode and automatic voltage control mode. In the VAR control mode, the shunt converter is controlled to draw an inductive or capacitive VAR, by controlling proper gating signals of the switching devices. Shunt converter current is fed back to shunt converter and keeps the DC capacitor voltage constant. In automatic voltage control mode, an external converter is attached at the point of connection to keep the regulated voltage at a certain range. Voltage is feedback to the shunt converter. The Power flow of the transmission line is controlled by injecting proper voltage in series with the transmission line using the series converter. Different working modes of the series converter are Direct voltage injection mode, Phase angle shifter emulation mode, Line impedance emulation mode, Automatic power flow control mode.

1. Direct voltage injection mode: The magnitude and phase angle of the series converter is controlled indirect voltage Injection mode.
2. Phase angle shifter emulation mode: In this mode, injecting a voltage to control the line voltage to get a specified Phase angle shift.
3. Line impedance emulation mode: injected voltage shouldbe proportional to the line current which results in an effective complex variable impedance.
4. Automatic power flow control mode: Real and reactive power can be automatically controlled by series of devices. Both real and reactive current- controlled separately by d-q transformation system. In this control mode,the line current act as a feedback signal to the control system.

In the Unified Power Flow Controller, Automatic voltage control mode is extensively usedfor the shunt converter and automatic power flow control mode for the series converter. In automatic power flow control mode, the UPFC control the magnitude of the voltage at the point of

connection by locally generating or absorbing the reactive power. Synchronously, the line transmitted power can be controlled by controlling the magnitude and phase angle of the injected voltage. This control mode is dominant compared with other types of UPFC devices.

The control scheme of the entire UPFC system is based on Automatic power flow control mode as shown in figure 3.1, that accepts operator input and power system real data. The Functional control block receives reference signals generated by system control based on the operator inputs and the power system data. The reference signals of the Functional control block consist of real and reactive power, the magnitude of the voltage at the POC and other reference signals. These reference signals with the real-time data, the shunt converter current, series converter output voltage, and the DC capacitor voltage employed to generate a current reference for the shunt converter control block and the voltage reference for the series converter control block. The converter control blocks use an appropriate reference signal to produce proper gating signals for the switching devices of two converters.

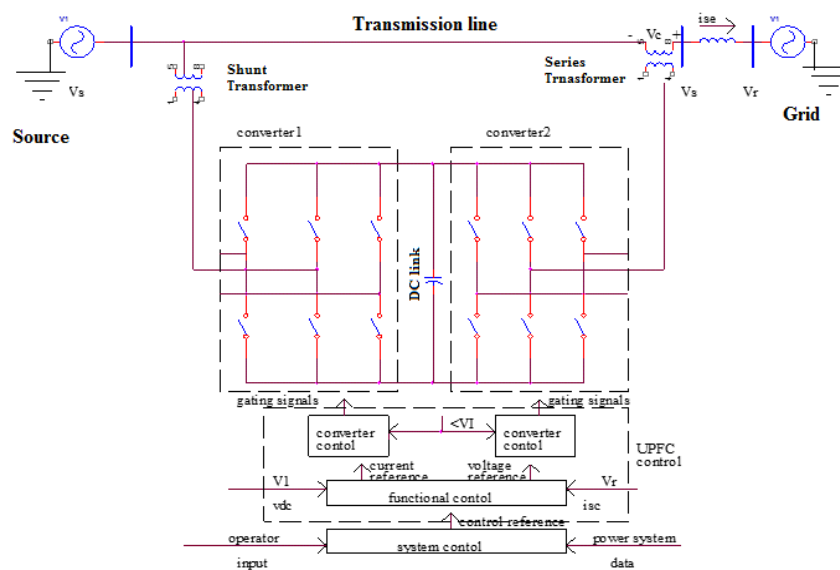

Figure 3.1 UPFC control system hierarchy

4. CONTROL VARIABLE REFERENCES FOR THE FUNCTIONAL CONTROL

This section depicts the function of the system control block that manipulates the operator inputs (control command) and the power system data to generate reference signals for the functional control block. Variables with a star symbol (*) superscript indicates a reference signals. Figure 4.1 shows the schematic description of unified power flow controller. Here P , Q , and v_1 are Control objectives of the system. Where P and Q represent real and reactive power flow of the transmission line and v_1 is the voltage magnitude controlled by the shunt device by injecting leading or lagging current into the point of connection illustrated as arrow 1 in Figure 4.1. The Power flow of the System P , and Q are controlled by injecting proper voltage into the transmission line through the series converter device as it exchanges real and reactive power with the system. In figure arrow 2 indicates the reactive power is exchanged locally with the DC capacitor bank. The function of the shunt device is to inject an active power into the transmission line via the DC capacitor bank. Arrow 3 in the diagram depicts the real power flow.

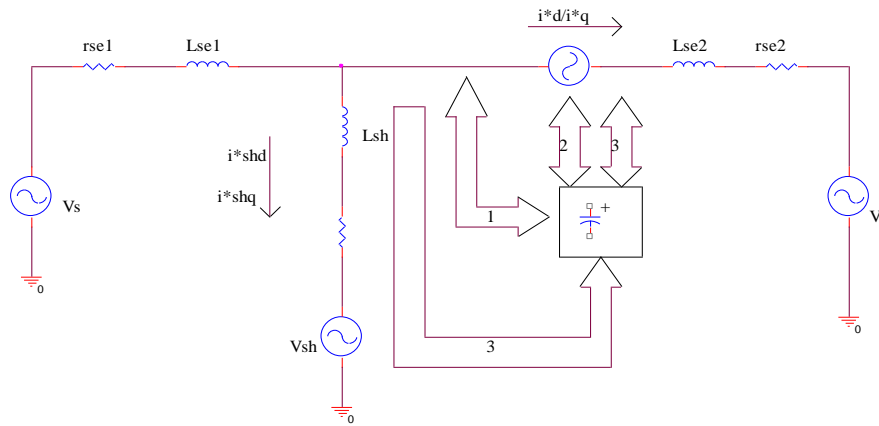

Figure 4.1 Power flow in a unified power flow controller

A. Series Current Computation

The real and reactive power is controlled separately by d-q transformation. For the three-phase d-q axis system, d-axis and q-axis reference current in the transmission line is calculated as equation (4.1)

$$\begin{cases} i^*_d = \frac{p^*}{v_{rd}} \\ i^*_q = \frac{q^*}{v_{rd}} \end{cases} \quad (4.1)$$

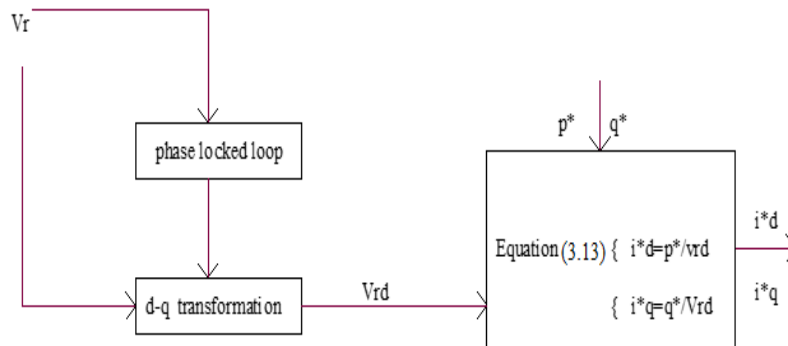

Figure 4.2 Series current converter

B. Shunt Current Computation

The magnitude of the sending end bus voltage v_1 is controlled by shunt device reactive power injection. So, q_{sh} can be controlled by a PI controller. The Reference value of q_{sh} is:

$$q^*_{sh} = \left(\frac{k_{iv}}{s} + k_{pv} \right) (|V_1|^* - |V_1|) \quad (4.2)$$

V_1^* is the reference voltage at the sending terminal and V_1 the real-time voltage. Integral gain and proportional gain of the PI controller are K_{iv} and K_{pv} . If the rotating axis is synchronous with the sending end voltage.

So, $V1^* = V1d$.

q -axis reference current,

$$shq = q * \frac{se}{vid} \quad (4.3)$$

The d-axis reference current for the shunt branch is decided by the active power Pse drawn by the series device. The shunt converter current is responsible for losses of power in the switching devices and the DC capacitor.

The DC capacitor voltage is constant.

$$i^*_{shq} = p^* \frac{se}{vid} + \left(\frac{k_{iv}}{s} + k_{pv} \right) (V^*DC - VDC) \quad (4.4)$$

d-axis component of the voltage at the point of connection is $V1d$. Instantaneous real power,

$$pse^* = v_{sed} + v_{seq}i_{shq}$$

Where, v_{sed} is the real component of the injected voltage.

i_{sed} and i_{seq} are the real and reactive components of the line current. The power stability region of the transmission line k_{iDC} and power Variation is k_{pDC} . Here, the DC capacitor bank is assumed to be an ideal capacitor. In practice, the capacitor has an Equivalent Series Resistance (ESR). The shunt device is used to compensate for the power loss due to ESR.

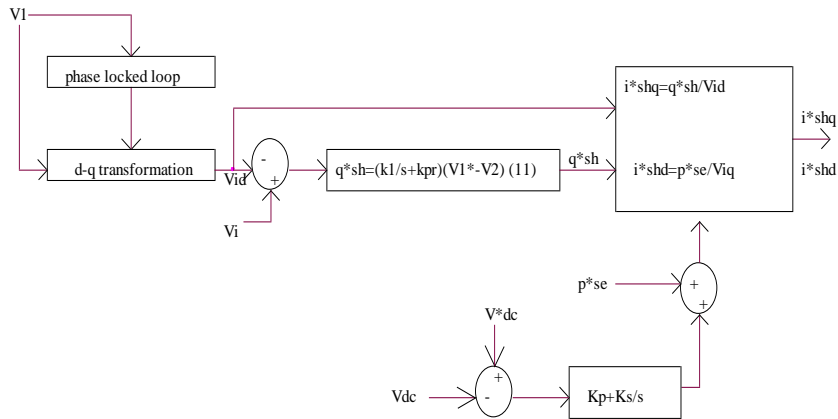

Figure 4.3 Shunt current reference computations

5. RESULTS AND DISCUSSION

A. Simulation Model of the UPFC System Using Proposed TIA

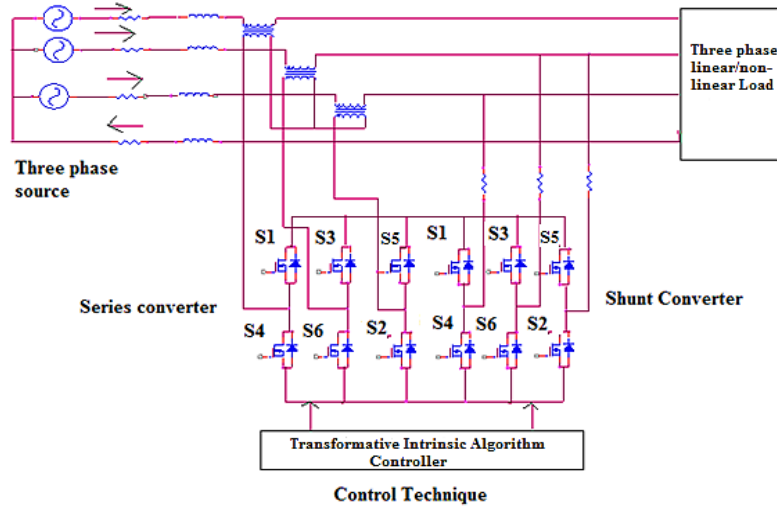

Figure 5.1 Simulink model of proposed system

The proposed UPFC based Transformative Intrinsic algorithm is developed by MATLAB Simulink software. MATLAB 2017a, operating software is the most common manipulation. Under various running conditions, TIA balances the power and maintains the direct voltage constant. Simulation results were compared with the improved algorithm.

B. Simulation sub-block diagram

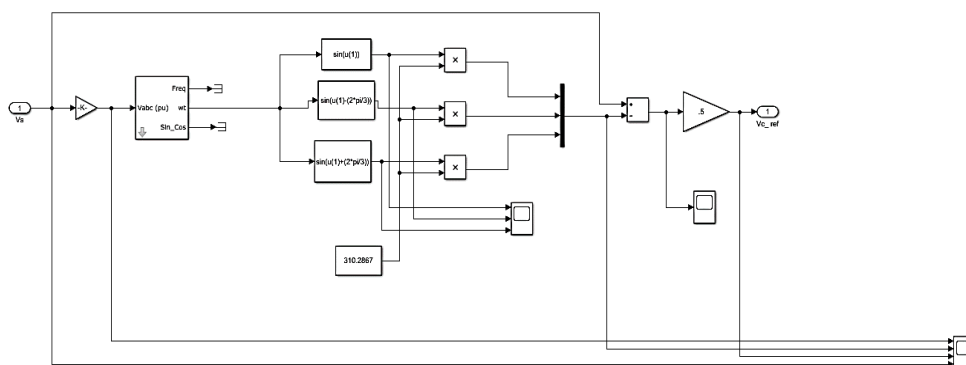

Figure 5.2 Voltage stabilizers Sub-block for the series converter

Figure 5.2 shows the voltage stabilizer sub-block for the series converter. This block will compare the voltage variation in the input and reference voltage. It will deliver the calculated current value to the hysteresis band control.

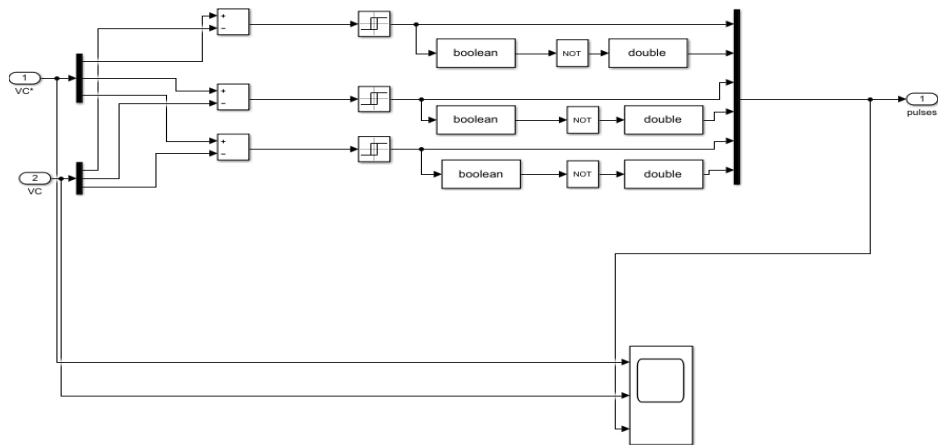

Figure 5.3 Hysteresis current control block for the series converter

Figure 5.3 shows the Hysteresis current control block for the series converter. This block will refer to the current from the voltage stabilizer circuit and produced proper PWM to the series converter.

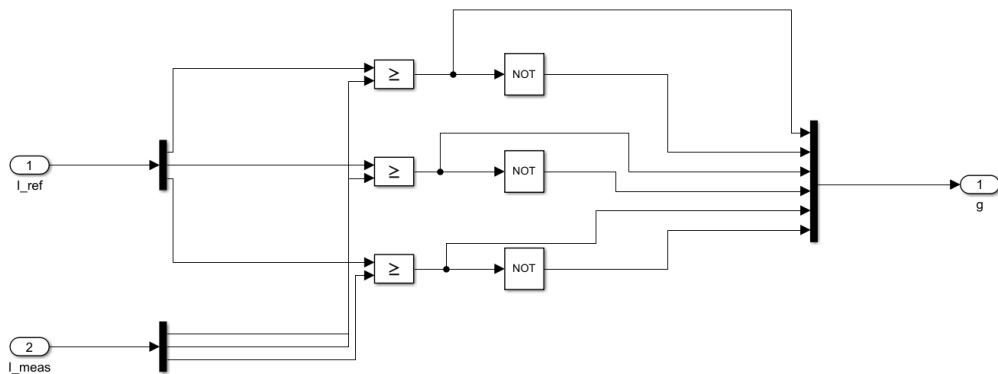

Figure 5.4 Hysteresis current control block for the shunt converter

The shunt converter sub-block has differed from the series converter, it will analyse the power variation from the TIA controller and produced effective variation in the Transmission system. Figure 5.4 shows the hysteresis current control block.

C. Voltage Sag

Voltage sag is called a voltage dip. The RMS Line Voltage nominal line voltage decreases from 10% to 90%. The voltage dip time gap is approximately 0.5 cycles of 1 minute.

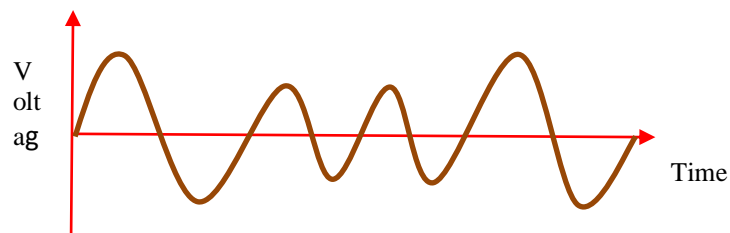

Figure 5.5 Voltage sag waveform

D. Voltage Swell

Voltage swell is also called voltage rise. The RMS line voltage increases from 1.1% to 1.8% of the nominal line voltage. The duration for voltage rise is around 0.5 cycles to 1 min. The voltage swell is caused due to the large capacitor bank energizing the large loads and shutting down.

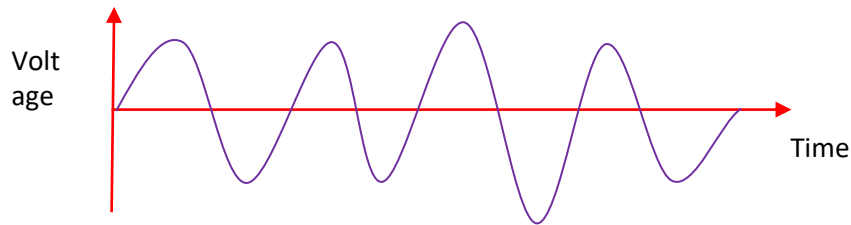

Figure 5.6 Voltage swell waveform

E. Voltage Fluctuations

Voltage Fluctuations in voltage are repeated or irregular variations in source voltage due to a sudden change in the magnitude of real and reactive power drawn by the load. The characteristics of voltage fluctuation depend upon the type of loads.

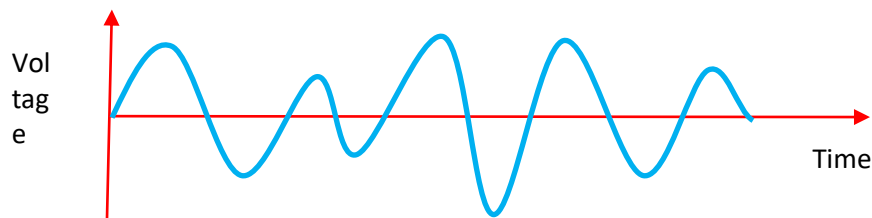
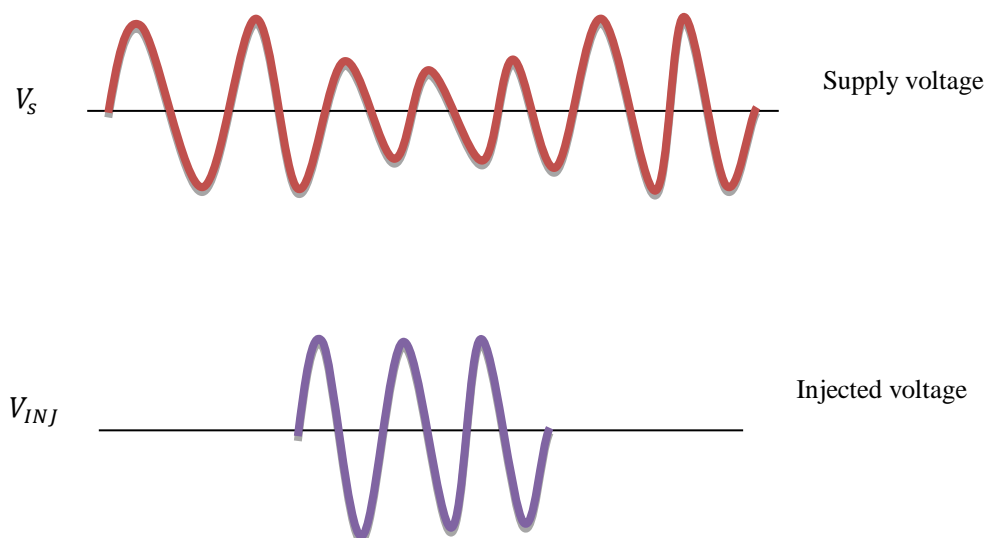

Figure 5.7 Voltage fluctuations



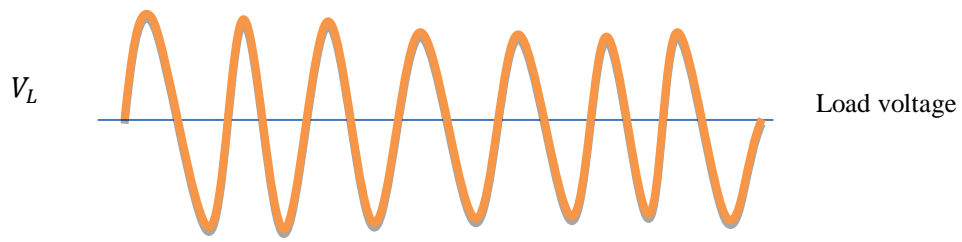

Figure 5.8 Waveform for the differential voltage system

6. SIMULATION RESULT AND ANALYSIS

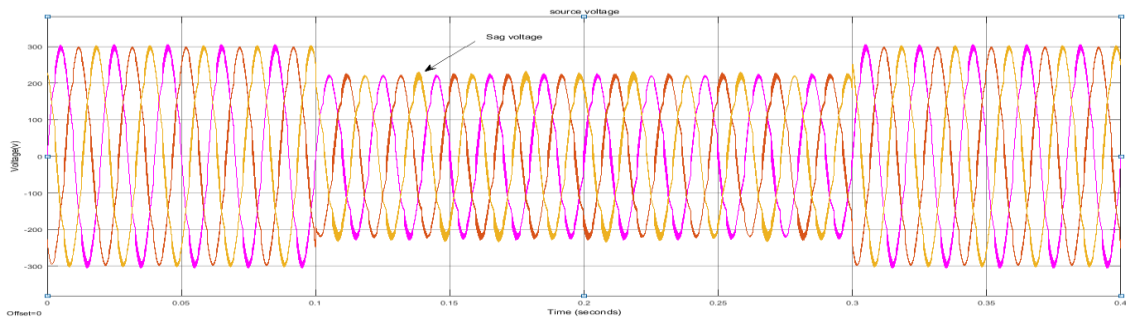

Figure 6.1 Simulated waveforms of source voltage for proposed UPFC model

Figure 6.1 shows the system Source voltage, which present voltage sag and the harmonic are high with a Damped oscillation waveform.

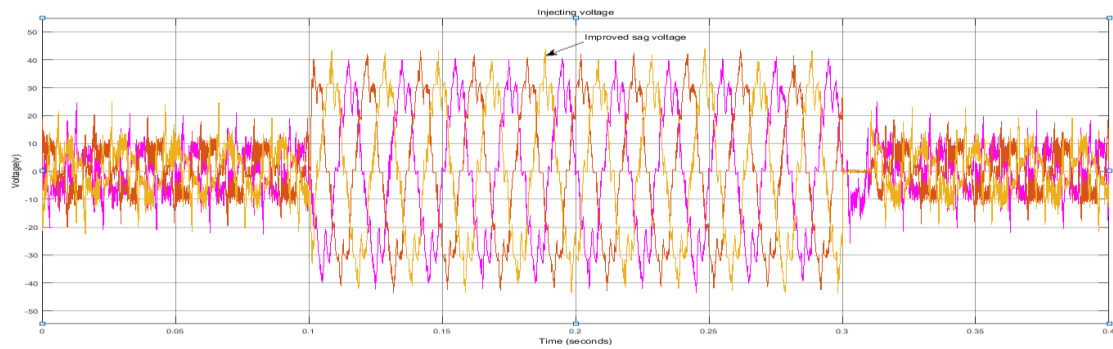

Figure 6.2 Simulated waveforms of injected voltage for proposed UPFC model

Figure 6.2 shows the system Injected voltage, of the UPFC system; this injected voltage will be used for reactive power for the proposed Simulink model.

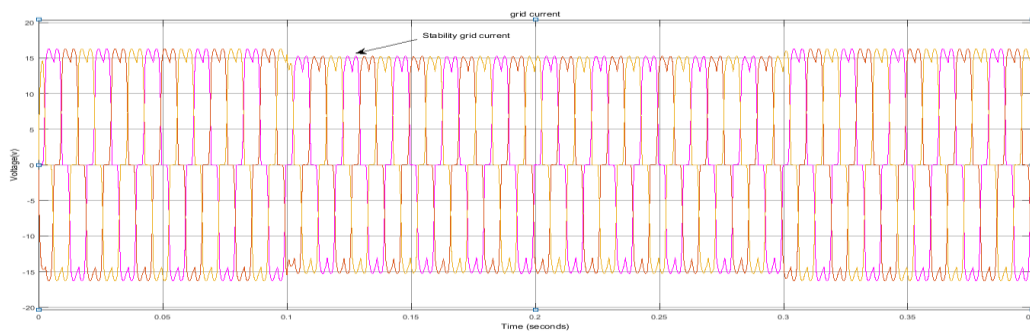

Figure 6.3 Simulated waveforms of grid current for proposed UPFC model

Figure 6.3 shows the current condition grid stability is analyzed to confirm the performance of the proposed under the UPFC, and the harmonics are low in this system.

7. CONCLUSION

This work introduced a new control concept of UPFC based on TIA to mitigate the problem functions like voltage sag, voltage swell, power factor, and Total Harmonics Distortion and improved the voltage in the transmission line. A Simulink modelling technique of the UPFC has been developed using shunt and series voltage sources. The performance of the proposed controller has been evaluated through dynamical and steady-state simulation, tests the fundamental positive sequence voltage provides not only with the grid voltage phase for the Voltage-Sourced Inverter parallel with the power grid but also the degree of the voltage unbalance of UPFC to compensate the unbalanced component fast. An exact power injection model is proposed based on the polar representation of the UPFC parameters and includes the reactive power capability of the shunt inverter. This reference injected voltage and current estimator compensated the reactive power at fundamental grid frequency, voltage and currents harmonics simultaneously and mitigates voltage dips and over-voltages. The real and reactive power flow in the transmission line could control using series injected voltage with controlled magnitude and phase angle. Hence all these parameters describe the effectiveness of the proposed system with TIA algorithm in power stability analysis of the transmission line.

REFERENCES

1. Rajendra, K, Pandey, Deepak Kumar Gupta 2018, 'Integrated Multi-stage LQR Power Oscillation Damping FACTS Controller' CSEE Journal of Power and Energy Systems, vol. 4, no. 1, pp. 83 – 91.
2. Kannan, S, Jayaram, S and Salama, MMA 2004, 'Real and reactive power coordination for a unified power flow controller,' IEEE Transactions on Power Systems, vol. 19, no. 3, pp. 1454–1461.
3. QuanruiHao and Jiufang Man 2018, 'Voltage Limit Control of Modular Multilevel Converter Based Unified Power Flow Controller Under Unbalanced Grid Conditions' IEEE Transactions on Power Delivery vol. 33, no.3, pp. 1319 - 1327.
4. Salmeron, S, and Litran, SP 2010, 'Improvement of the Electric Power Quality Using Series Active and Shunt Passive Filters" IEEE Transactions on Power Delivery, vol.25, issue. 2, pp. 1058 – 1067.
5. Wang Qi, Yi Jun and Liu Liping 2015, 'Optimal Control Strategy of a Unified Power Flow Controller Incorporated with an Active Power Source' in IEEE International Conference on Cyber Technology in Automation, pp. 4799-8730.

6. Yang Jianlin, Wang Rui 2016, 'The Study on the Application of the Unified Power Flow Controller for Shanghai Grid' in International Conference on Electricity Distribution, pp. 2161-749.
7. Ye Xiaohui & Chen Chuanbao 2017, 'Modeling and Simulation of Unified Power Flow Controller based on Modular Multilevel Converters' in Conference of the IEEE Industrial Electronics Society, pp. 5386-1127.
8. Axente, I Basu, M & Conlon, MF 2011, 'Dc link voltage control of UPQC for better dynamic performance,' Electric Power Systems Research, vol. 81, no. 9, pp. 1815–1824.
9. Mithilesh Singh and Shubhrata Gupta 2016, 'UPFC Facts Devices in Power System to Improve the Voltage Profile and Enhancement of Power Transfer Load ability' in International Conference on Power Electronics, pp. 4673-8587.
10. Moravej, Z, Pazoki, M 2014 'Impact of UPFC on Power Swing Characteristic and Distance Relay Behavior' in IEEE Transactions On Power Delivery, vol. 29, pp. 0885- 8977.

AUTHOR

K. Sindhu was born in India in 1980. She obtained her B.Sc. degree in Instrumentation in the year 2002 from Kerala University, India and she completed her M.Sc. degree in Instrumentation in the year 2004 from Bharathidasan University, India. She graduated with her M.E Degree in Applied Electronics in 2011, from Vinayaka Missions University, India. She received her Ph.D. Degree from Anna University in the year 2019, India. She is an IEEE member. Her research interests include Power system Analysis, Electrical, and Electronic Instrumentation, Embedded system, Communication systems, High Voltage Transmission, and Distribution System.

